

OPERATOER'S MANUAL
MULTI PURPOSE BAYONET SYSTEM (MPBS), M9

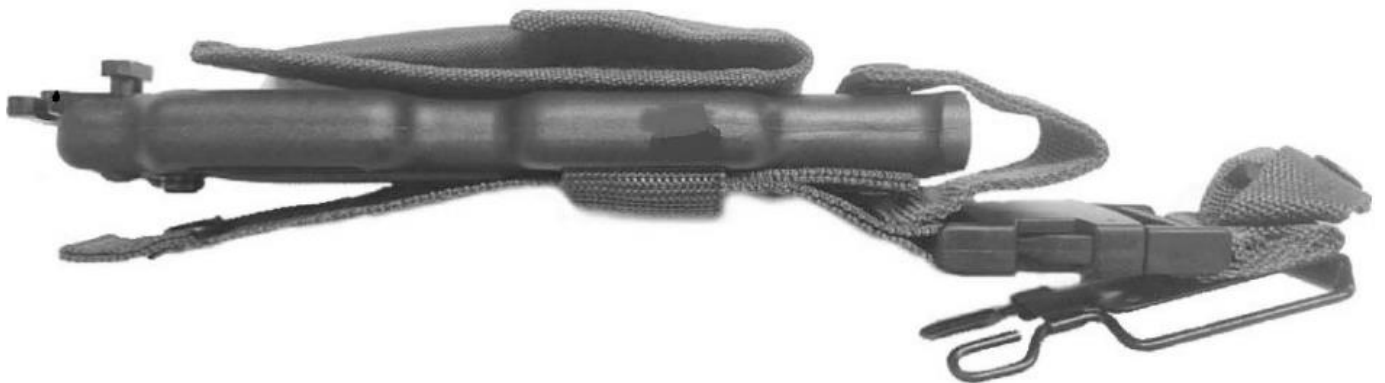
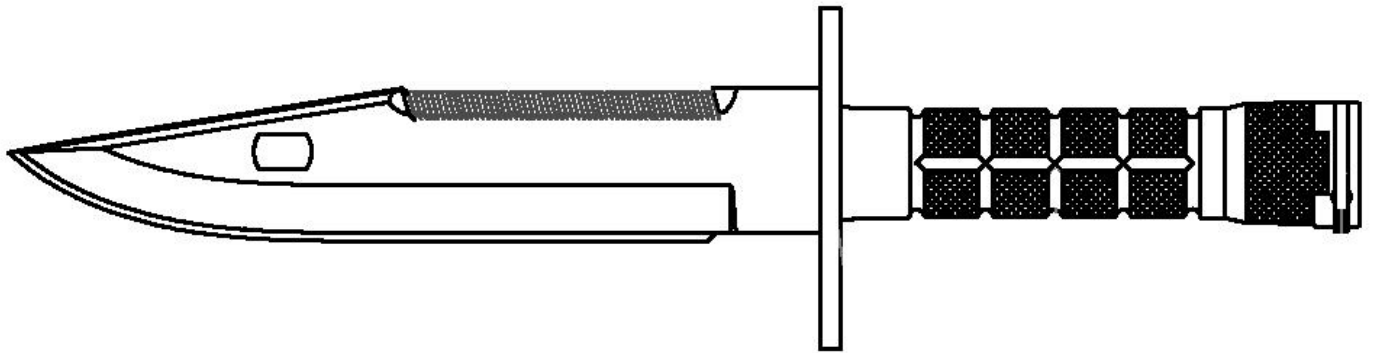

LINTON CUTLERY CO., LTD.

7F, No.332, Yongji Rd., Sinyi District, Taipei city, Taiwan (ROC)

Tel: +886.2.2767.2358

F: +886.2.2700.3978

Email: sales@armstek.com

WARNING

The blade of the bayonet is extremely sharp. Use it with care and discretion.

When using the MPBS as a wire cutter, care must be taken to avoid getting the fingers caught between the blade and the side of the scabbard body during the cutting stroke.

The bayonet is not insulated against electric shock. DO NOT use it to cut live wires.

The scabbard should be securely tied down to the leg when parachute jumping.

In the event of Nuclear, Biological, Chemical (NBC) contamination, remove the sharpening stone and discard it prior to implementing decontamination procedures. Remove it at any other time is not authorized.

INTRODUCTION:

The M9 Multi Purpose Bayonet System (MPBS) is designed to be used as a bayonet, fighting knife, general field and utility knife and wire cutter, in conjunction with its sheath.

EQUIPMENT DESCRIPTION:

The bayonet consists of 4 major parts: The blade, handguard, handle and latching mechanism.

In general outline, the blade is similar to the Bowie Knife; it is 7.125 inches long, 1.438 inches wide and .230 Inch thick. The blade is manufactured from 420 stainless steel and is hollow ground. It has a saw along its spine, a straight false edge which forms part of the cutting surface for the wire cutter, a 3.25 inch long fuller on its right side and an oval shaped wire cutter slot 2 inches from the point. A "T" shaped stud on the scabbard's wire cutter plate fits through this slot so the blade and scabbard can be mated together to form a wire cutter. The blade's spine has been machined with a saw, which is 3.90 inches long, .400 inch wide and has 46 teeth set .060 Inch apart. The saw is intended for emergency use, such as cutting through light non-ferrous metal. The entire surface of the blade has been glass bead blasted to give it a dull, non-reflective finish.

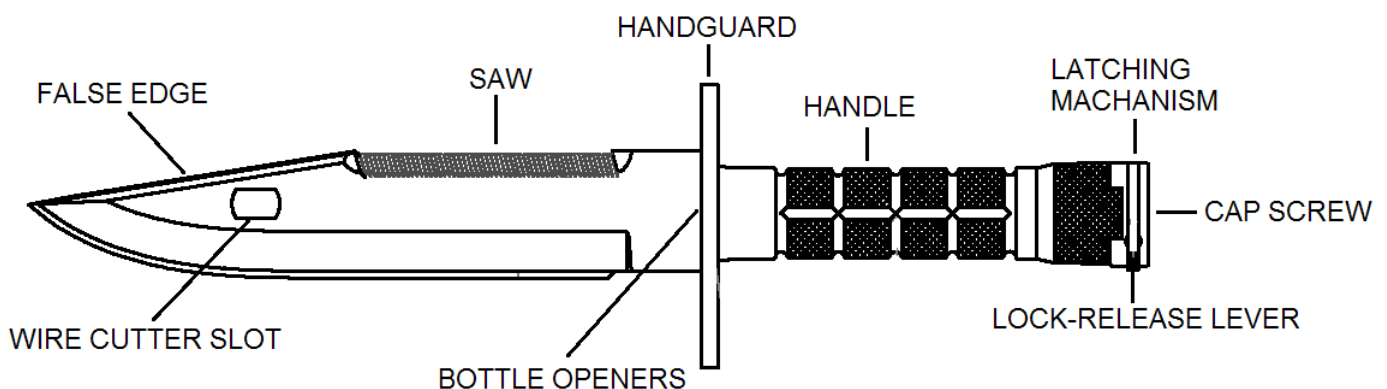

Caution

KEEP THE SCABBARD BODY, HANDLE AND WEB GEAR AWAY FROM OPEN FLAMES

The handguard is .188 inch thick and has been given a dull oxide finish to make it non-reflective. The flat side of the handguard, facing the blade, has been machined with 2 shallow cuts which are designed to be used for opening bottle caps.

The handle is manufactured from glass-fiber-filled Nylon. It is resistant to breakage and deformation between the temperature extremes of minus 50 degrees Fahrenheit to plus 140 degrees Fahrenheit. The handle has been grooved and knurled to provide a secure grip under battlefield conditions.

The latching mechanism is secured to the handle with a steel cap screw and 2 steel roll pins, and has been given an oxide finish to make it non-reflective.

The scabbard assembly consists of 5 major parts: The scabbard body, wire cutter plate, belt fastener, web gear and pouch.

The scabbard body is manufactured from the same material as the handle. It is fitted with a stainless steel internal spring friction device designed to securely retain the bayonet blade and prevent it from rattling or being inadvertently lost. A sharpening stone is inlaid into the back of the scabbard. The stone is provided to maintain the cutting edge of the bayonet.

The black oxide finished wire cutter plate is manufactured from hardened stainless steel and is provided with a "T" shaped stud which forms the pivot point for the wire cutter and a screwdriver lip.

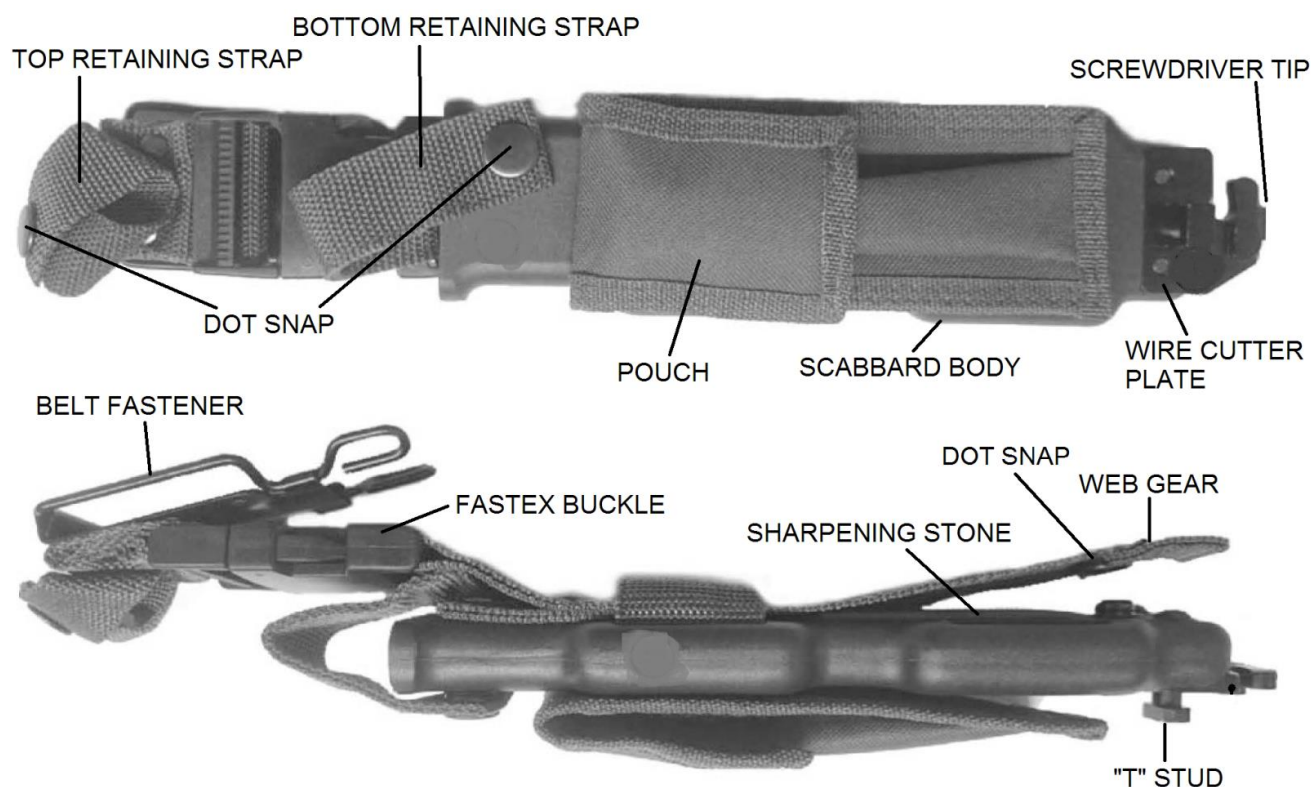

EQUIPMENT DESCRIPTION: (Cont.)

The web gear is manufactured from olive drab colored scuba nylon webbing, a FASTEX quick detachable buckle, dot snaps and a belt fastener. The web gear has been fitted with 2 straps to secure the bayonet. The top one loops around the handle and the bottom one fastens over the handguard. The bayonet and scabbard can be quickly detached from the belt fastener. A webbing strap runs down the back of the scabbard body which covers and protects the sharpening stone and is secured with a dot snap.

The pouch is designed to hold an extra M9 9mm Pistol magazine or other small items.

PREVENTIVE MAINTENANCE CHECKS & SERVICES (PMCS)

NOTE

An inactive weapon is a weapon, whether assigned or not assigned to an individual, that is stored in an arms room for a period of 90 days. Normal cleaning (PMCS) of an inactive weapon will be performed every 90 days.

Perform PMCS if you are the assigned operator and the bayonet has been stored in the arms room and not used for a period of 90 days, or you have been issued the bayonet for the first time.

Always keep in mind the CAUTIONS and WARNINGS.

All inspections will be visual, without the aid of magnification.

OPERATOR PREVENTIVE MAINTENANCE CHECKS AND SERVICES

Warning

The blade of the bayonet is extremely sharp. Use it with care and discretion.

ITEM ITEM TO BE INSPECTED:

NO. EQUIPMENT NOT READY/AVAILABLE IF:

ACTIONS REQUIRED

BAYONET

1. Check function of lock-release levers by placing bayonet on rifle bayonet lug. Ensure bayonet is securely retained, and mounts and dismounts without interference. Remove bayonet from rifle.

Bayonet is not securely retained or interference is observed during installing or removal.

Turn in to the unit armorer.

2. Inspect blade for cracks, nicks, or blunted points.

Cracked blade; deep nicks or blunted points that cannot be restored by stoning.

Turn in to the unit armorer.

3. Inspect/check handguard for cracks or looseness.

Cracked or loose handguard.

Turn in to the unit armorer.

4. Inspect handle for cracks, breaks, or looseness.

Cracked, loose, or broken handle.

Turn in to the unit armorer.

5. Inspect for broken or dulled saw teeth.

If 1/4 of the saw teeth are broken or worn badly enough to be non-functional.

Turn in to the unit armorer.

6. Inspect for broken, cracked, or chipped "False Edge" on blade.

False Edge broken, cracked, or chipped.

Turn in to the unit armorer.

7. Inspect for loose, cracked, or broken cap screw.

Cracked, broken, or loose cap screw.

Turn in to the unit armorer.

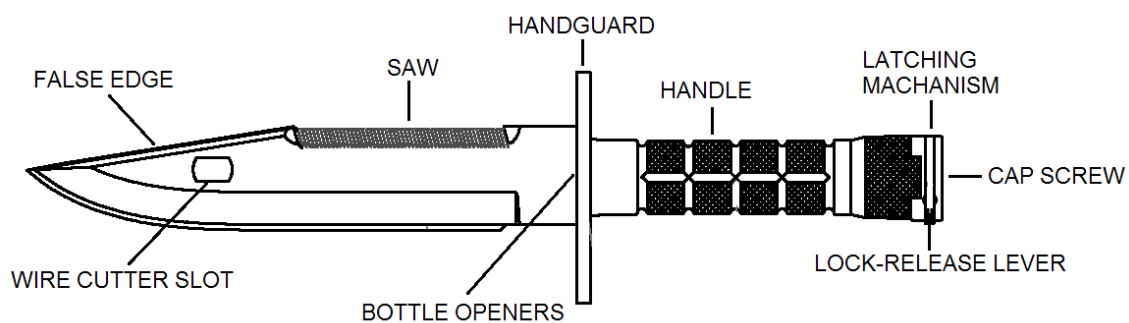

ITEM ITEM TO BE INSPECTED:
 NO. EQUIPMENT NOT READY/AVAILABLE IF:
 ACTIONS REQUIRED

SCABBARD

8. Inspect for cut web gear, pouch, or retaining strap.
 Cuts over 1/4 inch deep.
 Turn in to the unit armorer.
9. Inspect for cracked or broken FASTEX Buckle.
 FASTEX Buckle cracked or broken.
 Turn in to the unit armorer.
10. Inspect for cracked or broken scabbard body.
 Broken scabbard body with pieces missing or cracks over 1/2 inch in length.
 Turn in to the unit armorer.
11. Inspect for bent or broken Belt Fastener.
 Belt Fastener will not securely fasten the scabbard to the belt.
 Turn in to the unit armorer.
12. Inspect for cracked or broken Screwdriver Tip or Wire Cutter Plate/Stud.
 Broken, cracked or missing screwdriver tip or wire cutter plate/stud.
 Turn in to the unit armorer.
13. Inspect Dot Snaps to insure they function.
 Dot Snaps do not function.
 Turn in to the unit armorer.

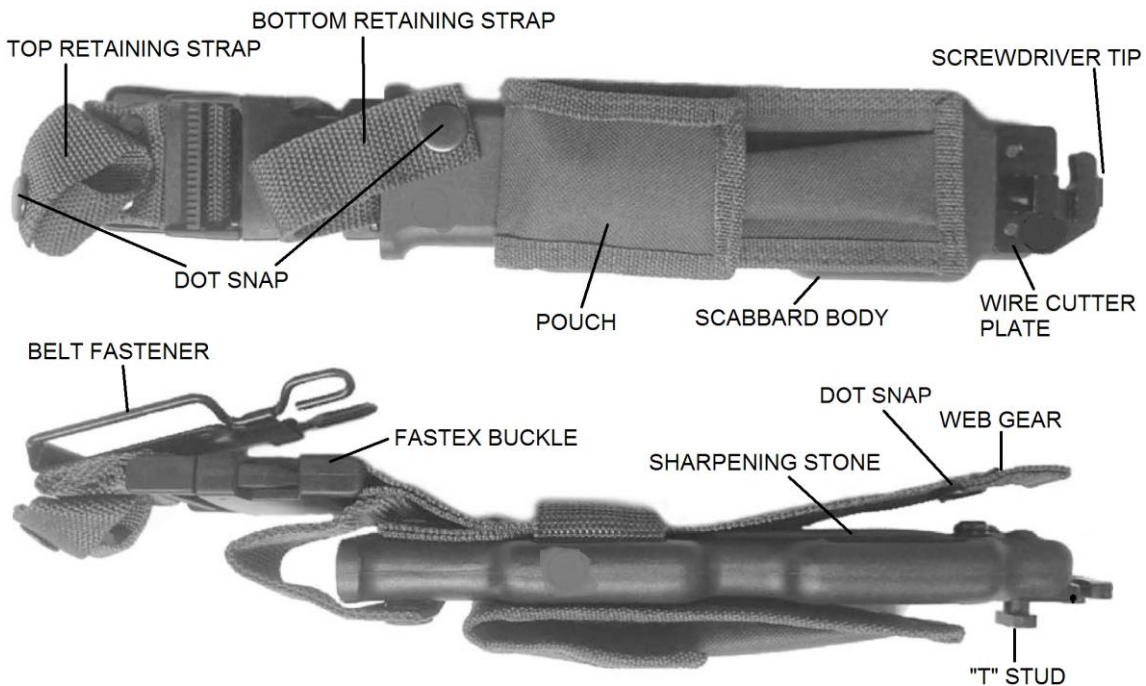

OPERATING INSTRUCTIONS:

Warning

The blade of the bayonet is extremely sharp. Use it with care and discretion.

Caution

Take care not to cut the web strap when removing or inserting the bayonet in the scabbard.

Field Carry:

The bayonet should be inserted into the scabbard so the bottom restraining strap goes over the small end of the handguard, not over the muzzle ring. The MPBS should be carried with both web restraining straps fastened around the bayonet. The top strap can be undone to allow freedom of movement; for example when sitting in a vehicle.

Mounting on the Rifle:

Withdraw the bayonet from the scabbard. Present the bayonet to the muzzle of the rifle so the muzzle ring fits around the flash suppressor and the latching mechanism engages the bayonet lug on the rifle barrel. Pull to the rear so the latching mechanism locks onto the bayonet lug. With the bayonet pointing in a SAFE direction, pull forward on the bayonet to insure it is firmly attached to the rifle.

Removing from the Rifle:

With the rifle pointing in a SAFE direction, depress the lock-release latch on each side of the latching mechanism and pull forward on the bayonet to remove it from the rifle. Return the bayonet to the scabbard.

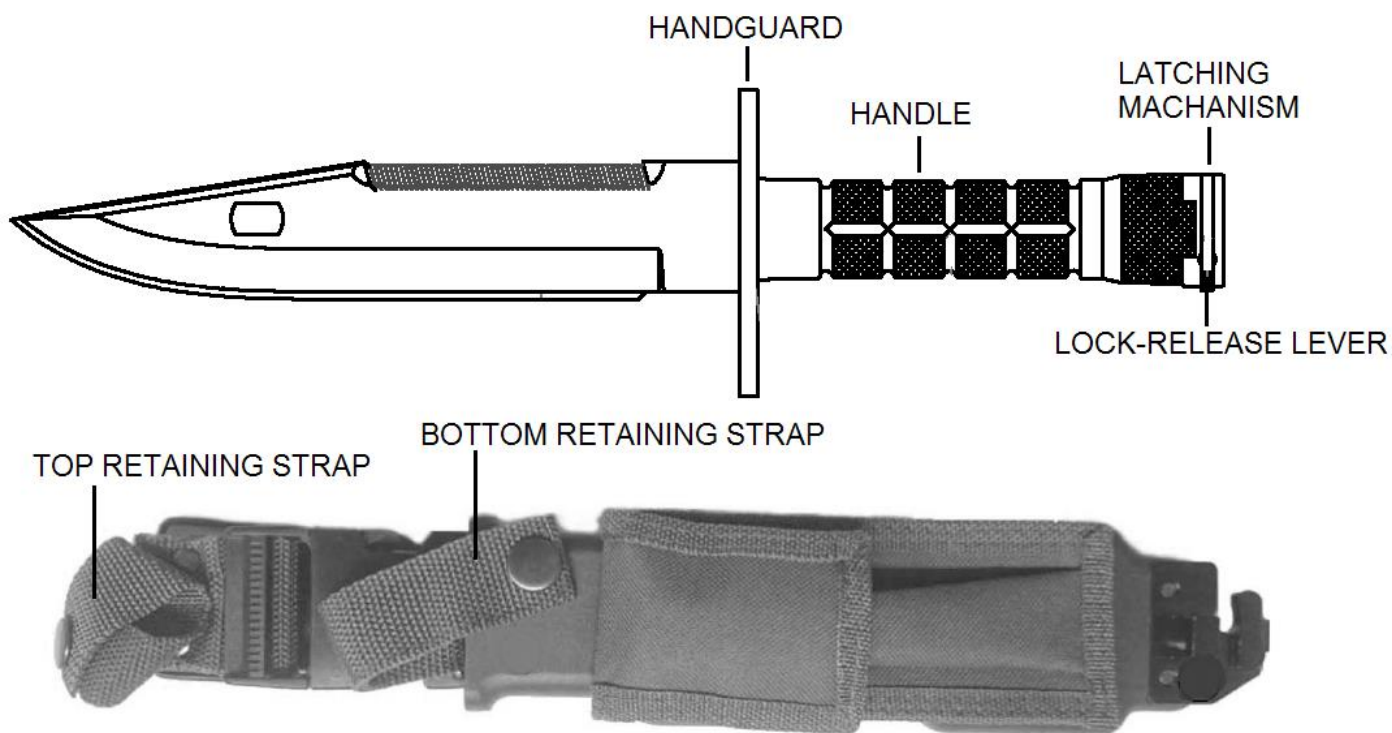

Warning

The blade of the bayonet is extremely sharp. Use it with care and discretion.

The bayonet is not insulated against electric shock. DO NOT use it to cut live wires.

When using the MPBS as a wire cutter, care must be taken to avoid getting the fingers caught between the blade and the side of the scabbard body during the cutting stroke.

Quick detach of Bayonet and Scabbard:

Undo the top restraining strap around the bayonet's handle. To separate the bayonet and scabbard from the belt fastener, depress the latch on both sides of the FASTEX buckle and pull down on the bayonet scabbard, leaving the top part of the web gear and belt fastener in place on the belt. To return the scabbard to its position on the belt fastener, insert the lower part of the FASTEX buckle into the upper portion of the buckle and press upward until it snaps. Pull down on the scabbard to insure it is firmly attached. Insert the bayonet and fasten the restraining straps around the bayonet's handle.

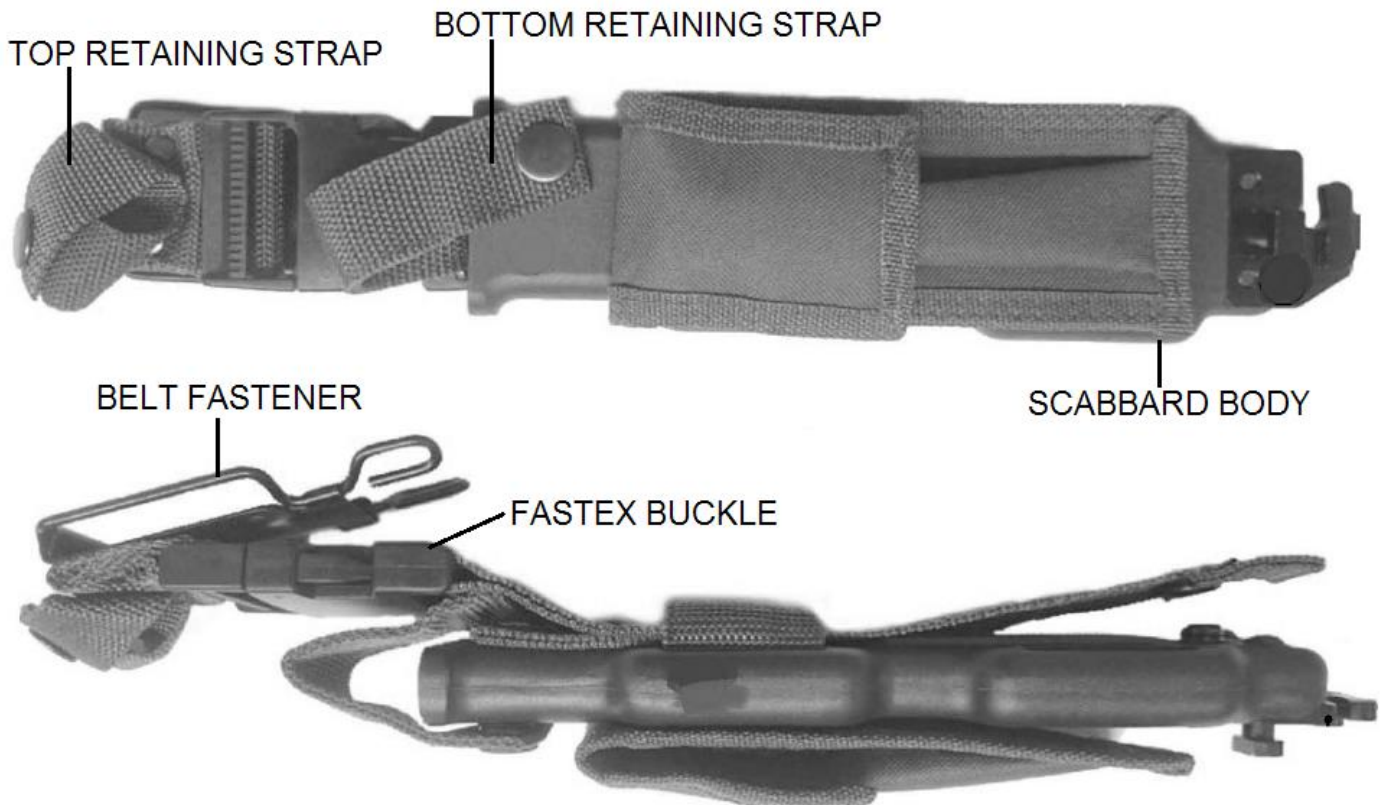

Warning

The blade of the bayonet is extremely sharp. Use it with care and discretion.

NOTE

The wire cutter should only be used to cut wire or similar material. It is not a bolt cutter and should not be used on hardened materials.

Using the Wire Cutter:

Detach the bayonet and scabbard from the belt fastener. Withdraw the bayonet from the scabbard. The scabbard must be held with the left hand, grasping the throat of the scabbard and the wire cutter plate "T" stud on top. With the bayonet in the right hand, so the saw (the side without the fuller groove) is on top, place the oval shaped wire cutter slot over the "T" stud and press down so the flat surfaces of the blade and wire cutter plate lie flush together. The wire cutter plate has a slot machined into one edge. Position the wire all of the way into this slot. Using care not to catch your fingers between the blade and the side of the scabbard, press the blade and scabbard together in a scissors action to cut the wire. Separate the bayonet from the scabbard. Return the bayonet to the scabbard and attach the scabbard to the belt fastener.

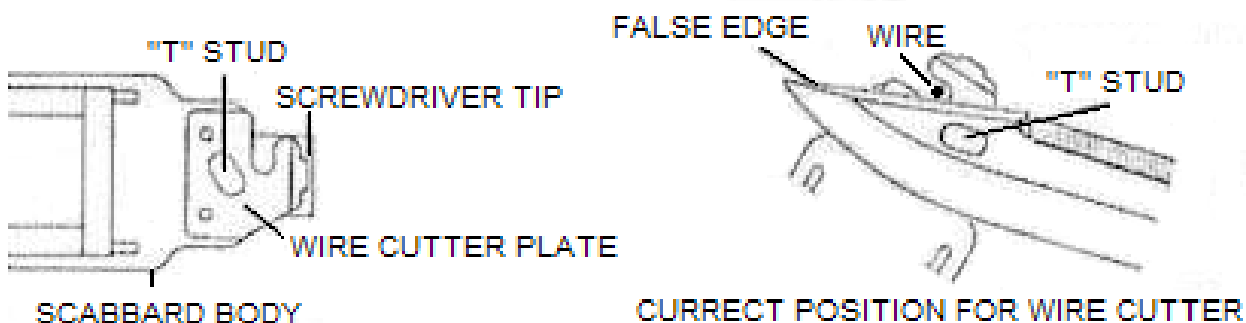

Using the Bottle Opener:

The handguard has two shallow cuts machined into its forward surface on both sides of the blade. Place the flat side of the blade over the bottle cap with the edge pointing away from your body and hook one of the cuts under the lip of the bottle cap. Lever upwards with sufficient force to pop the cap off the bottle.

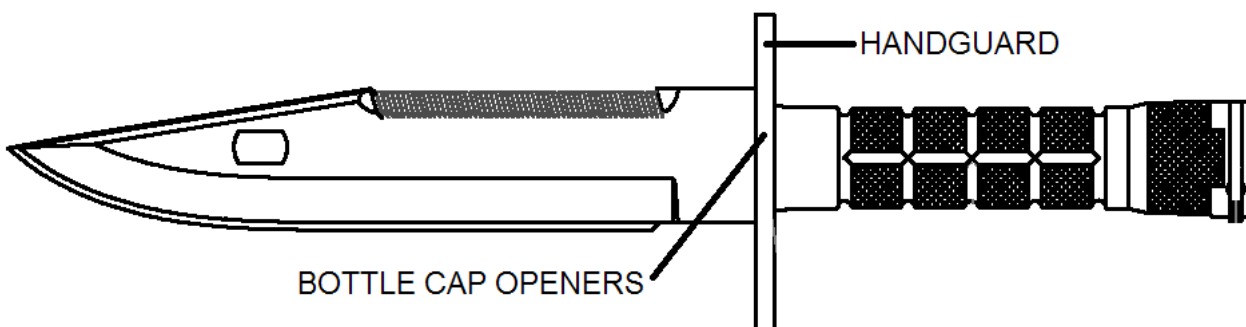

Warning

The blade of the bayonet is extremely sharp. Use it with care and discretion.

Using the Screwdriver:

Detach the bayonet and scabbard from the belt fastener. Leave the bayonet in the scabbard to add additional support to the scabbard during use as a screwdriver. After use, return the scabbard to the belt fastener.

SCREWDRIVER TIP



Note

The saw is intended for emergency use in cutting through such materials as light non-ferrous metal, wood, and plastic. The saw should not be used on ferrous metal such as steel and iron. For best operation of the saw during use, the saw teeth must be kept free from particles of the material being cut. Any small, stiff brush may be used for this cleaning.

Warning

The blade of the bayonet is extremely sharp. Use it with care and discretion.

Using the Saw:

Remove the bayonet from the scabbard and use the saw portion of the blade. Clean the bayonet (see Cleaning and Lubrication, page 10), paying close attention to the saw teeth and blade. Return the bayonet to the scabbard.

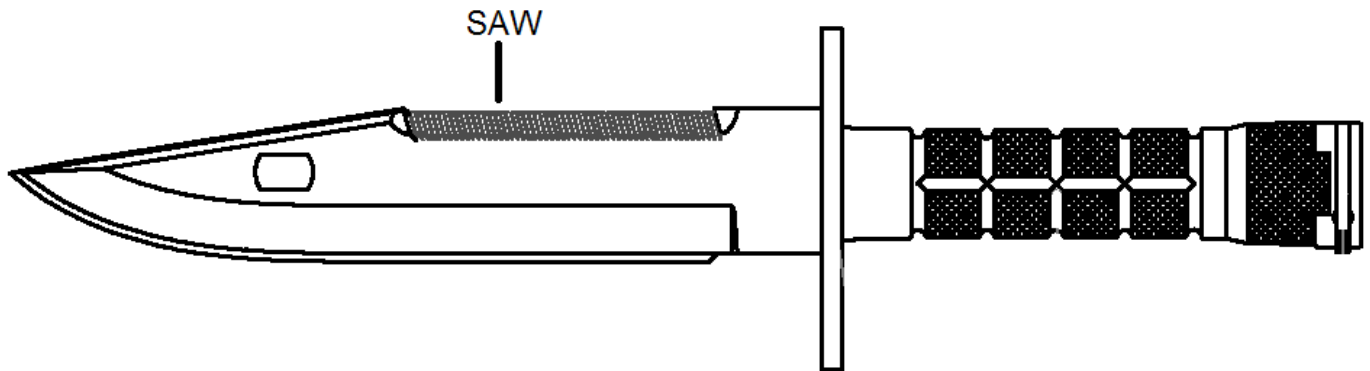

MAINTENANCE INSTRUCTIONS:

Warning

The blade of the bayonet is extremely sharp. Use it with care and discretion.

Note

Other than the procedures depicted in this manual, NO DISASSEMBLY OF THIS BAYONET OR SCABBARD IS AUTHORIZED BY ANY LEVEL OF MAINTENANCE. (No repairs or repair parts are authorized)

For the purpose of this manual, the term "OIL" shall be interpreted to mean any oil/lubricant authorized for use on the weapon assigned to the user.

Caution

Take care not to cut the web strap or the dot fastener during the following procedures.

Sharpening the Blade:

Remove the bayonet from the scabbard and the scabbard from the belt fastener. Unfasten the web strap covering the sharpening stone. Leaving the sharpening stone in place (attached to the scabbard), lubricate the surface of the sharpening stone with oil. The purpose of the oil is to prevent the stone from becoming clogged with the small steel particles removed from the blade.

Sharpening the Blade: (Cont.)

Start at one end of the stone, draw the edge of the blade toward you from one end of the stone to the other, making one smooth continuous pass so the entire edge of the blade is covered from rear to point. After this first stroke, reverse the blade and repeat the same action on the other side, only this time from the point to rear, starting at the near end of the stone and moving away from you. Maintain the same sharpening angle throughout the process on both sides. (A 20 degree angle between the blade and the stone is optimum.) Make an equal number of strokes on each side. After using the sharpening stone, wipe it clean and secure the web strap over it. Lubricate the blade of the bayonet. Return the bayonet to the scabbard and attach the scabbard to the belt fastener.

Note

The MPBS does not require disassembly for routine cleaning, maintenance or preservation. The cap screw, web gear and cutter plate screws are all secured with LOCKTITE 271. Disassembly is not authorized.

Cleaning and Lubrication:

The blade and other metal parts of the MPBS should be cleaned and preserved with a light coat of oil.

The scabbard, handle and web gear can be cleaned with water and a mild detergent or soap. Rub or brush clean with a soft bristle brush. Do not use abrasives, steel wool or stiff wire brushes on these parts. Wipe dry with a rag or cloth and apply a light coat of oil to all exposed metal parts.